

A partir de PL 1400, puerta de cabina con dos motores  
From a CO 1400, cabin door with two motors  
Desde PL 600 hasta PL 900 utilizar cotas con asterisco (\*)  
From CO 600 to CO 900 use measures with asterisk (\*)

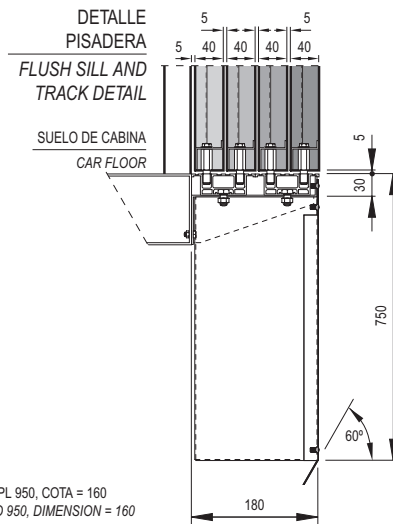
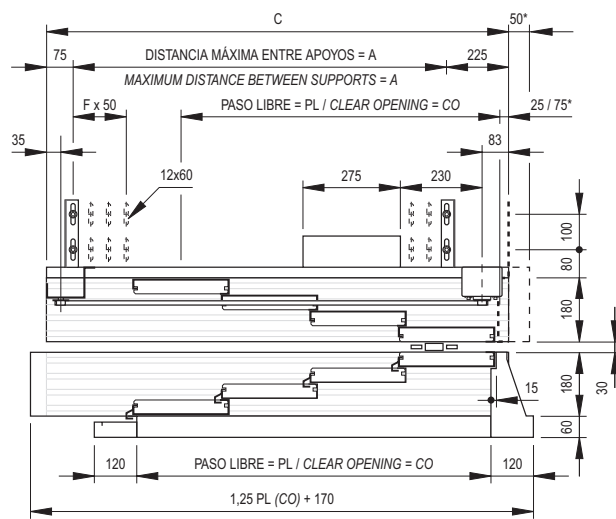
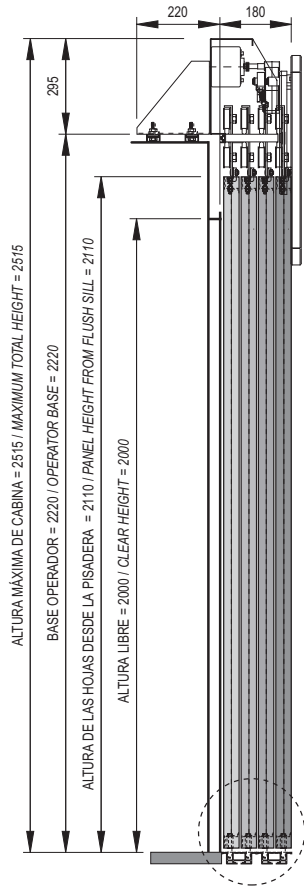
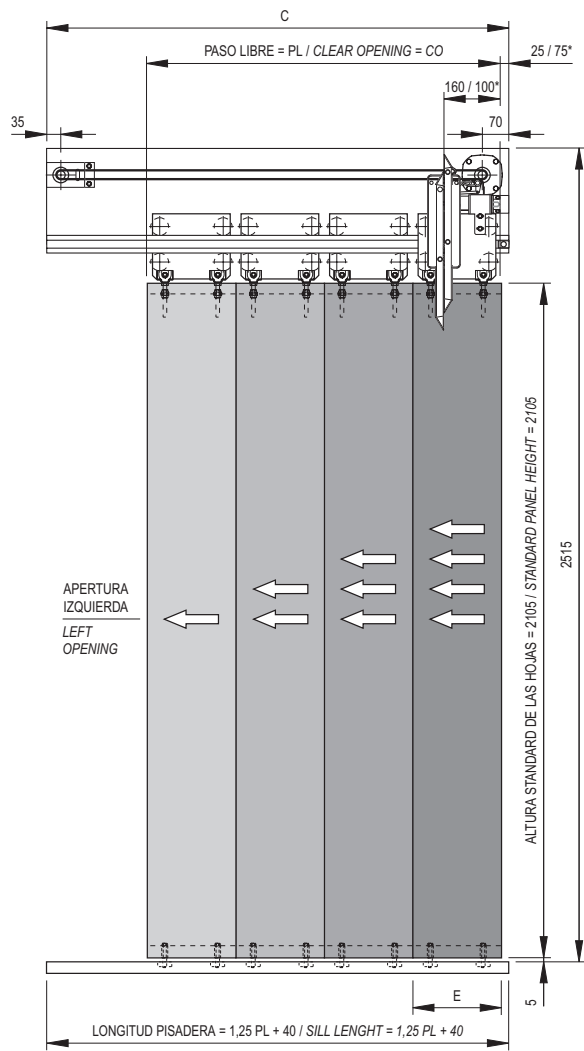

\*: A PARTIR DE PL 950, COTA = 160  
\*: FROM THE CO 950, DIMENSION = 160

PL / CO	600*	650*	700*	750*	800*	850*	900*	1000	1100	1200	1300	1400	1500	1600	1700	1800	1900	2000
A	505	570	630	695	755	820	880	1005	1130	1255	1375	1500	1625	1705	1830	2055	2180	2305
C	850	910	975	1035	1100	1160	1225	1300	1425	1550	1675	1800	1925	2050	2175	2300	2425	2550
E	170	182	195	207	220	232	245	270	295	320	345	370	395	420	445	470	495	520
F	3	3	4	4	4	4	5	6	7	8	9	9	10	6	6	6	6	6
TIEMPO / TIME (s)	1,56	1,62	1,68	1,74	1,8	1,85	1,91	2,01	2,11	2,2	2,3	2,4	2,5	2,6	2,7	2,8	2,9	3
PESO / WEIGHT (kg)	61,5	67	72	77	82	87,5	92,5	102,5	113	123	133,5	143,5	154	164	174,5	184,5	195	205

■ : Con semiautomática / With semiautomatic : C - 50 mm.

\*: Consultar con nuestro departamento técnico - To be consulted to our technical department.