

A partir de PL 1400, puerta de cabina con dos motores  
From a CO 1400, cabin door with two motors

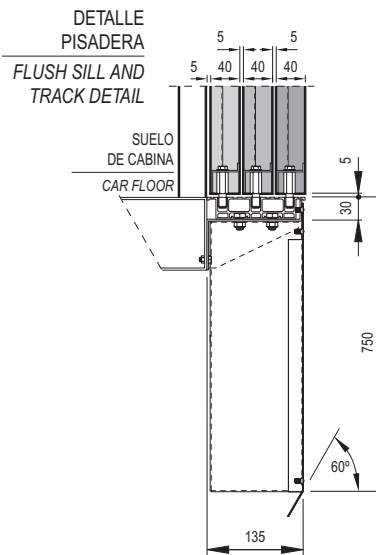
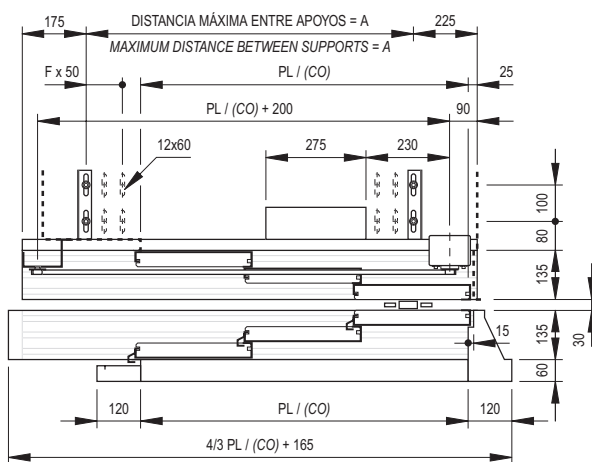
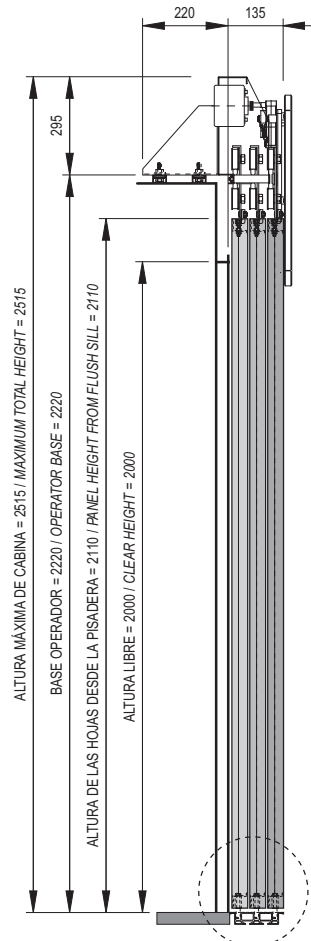
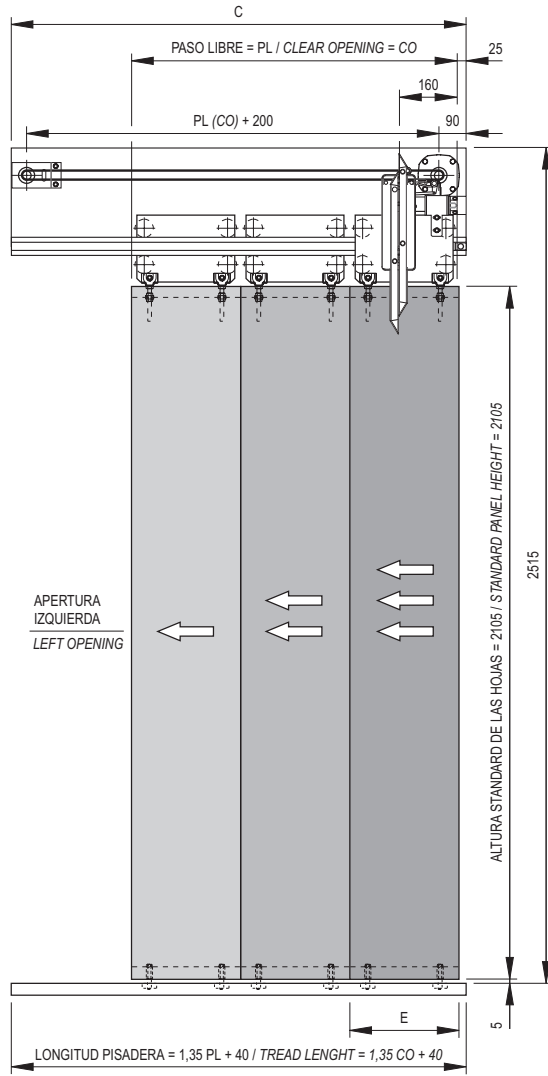

PL / CO	600	650	700	750	800	850	900	1000	1100	1200	1300	1400	1500	1600	1700	1800	1900	2000
A	495	545	595	645	720	795	845	995	1145	1295	1395	1545	1695	1795	1945	2045	2195	2345
C	895	945	995	1045	1120	1195	1245	1395	1545	1695	1795	1945	2095	2195	2345	2445	2595	2745
E	220	235	253	270	285	305	320	352	385	420	453	485	520	553	585	620	653	685
F	4	4	4	4	4	4	4	4	4	5	5	6	6	6	6	6	6	6
TIEMPO / TIME (s)	1,56	1,62	1,68	1,74	1,8	1,85	1,91	2,01	2,11	2,2	2,3	2,4	2,5	2,6	2,7	2,8	2,9	3
PESO / WEIGHT (kg)	57	61,5	66	71	75,5	80,5	85	94,5	104	113,5	123	132,5	142	151	160,5	170	179,5	189