

Puerta con frontis
Door with infill panels

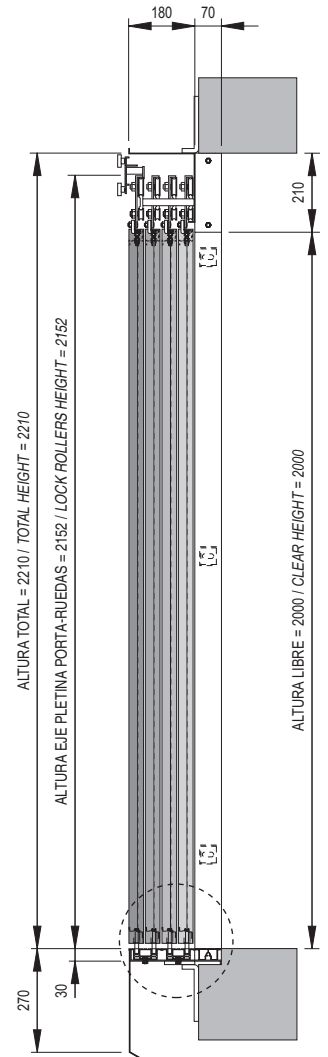

DETALLE
PISADERA
FLUSH SILL AND
TRACK DETAIL

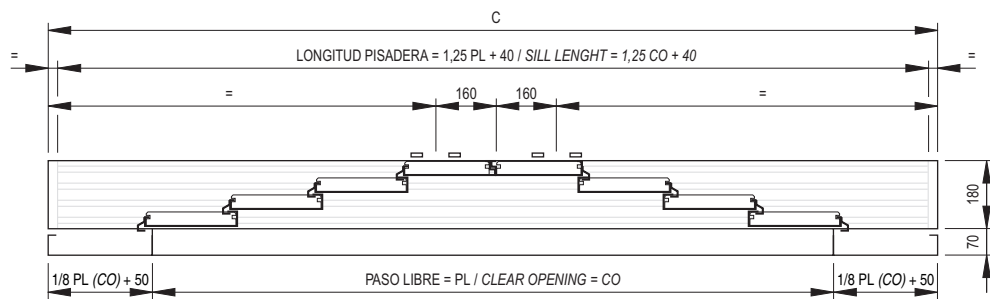
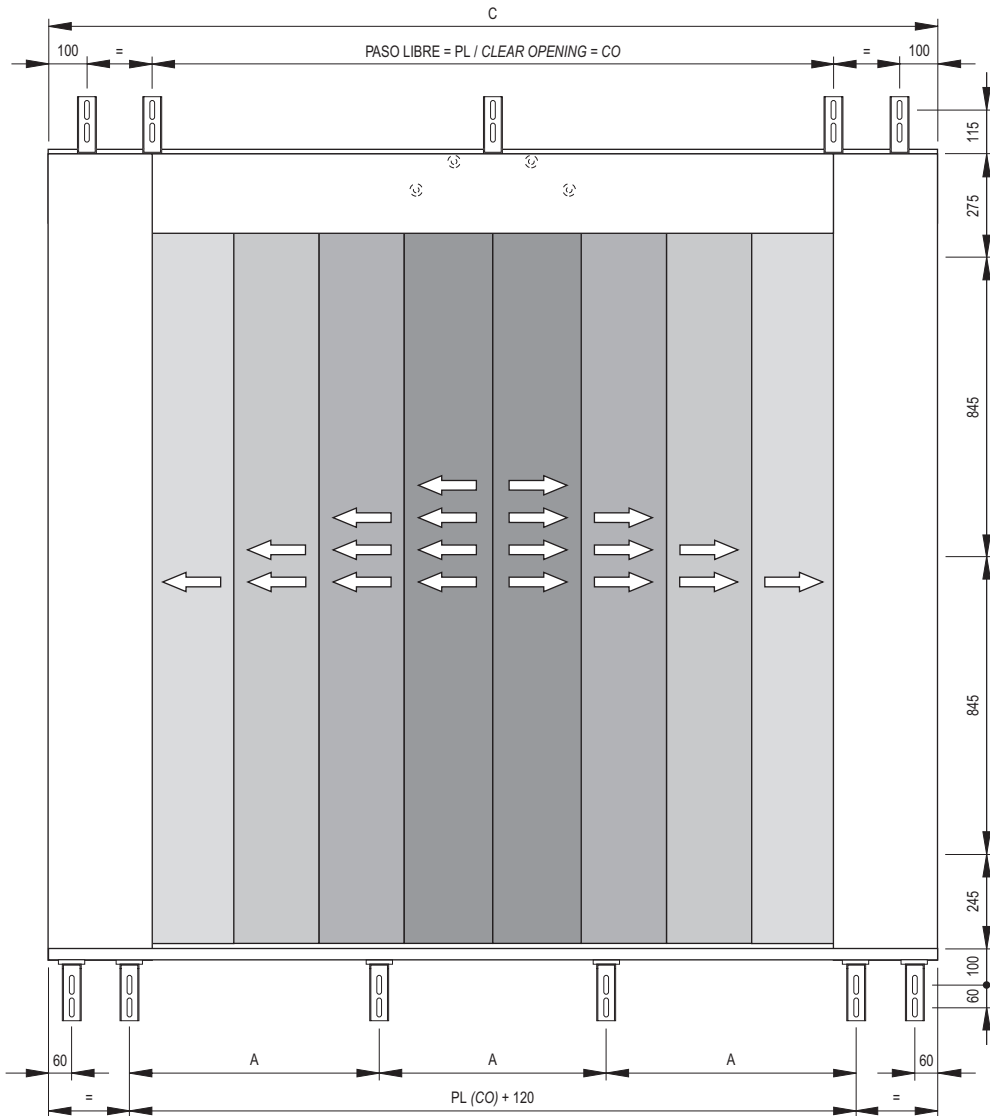
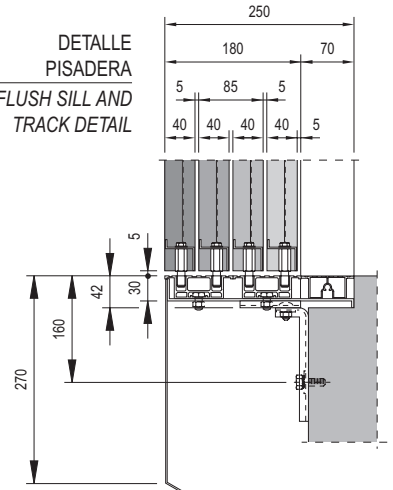

4

PL / CO	1400	1500	1600	1700	1800	1900	2000	2100	2200	2300	2400	2500	2600	2700	2800	2900	3000
A	380	324	344	364	384	404	353	370	387	403	360	374	340	352	365	377	390
C	1850	1975	2100	2225	2350	2475	2600	2725	2850	2975	3100	3225	3350	3475	3600	3725	3850
S	5	5	6	6	6	6	7	7	7	7	8	8	9	9	9	9	9
T	10	10	11	11	12	12	13	13	13	13	15	15	16	16	16	16	17

S: N°. de soportes en apoyo pisadera.
S: Number of supports for support track.

T: N°. de soportes total.
T: Total number of supports.