

1.2.

PUERTA RELLANO CENTRAL 2 HOJAS 2 PANEL CENTRE PARTING LANDING DOOR

40/10

Fermator
AUTOMATIC DOORS FOR LIFTS

1

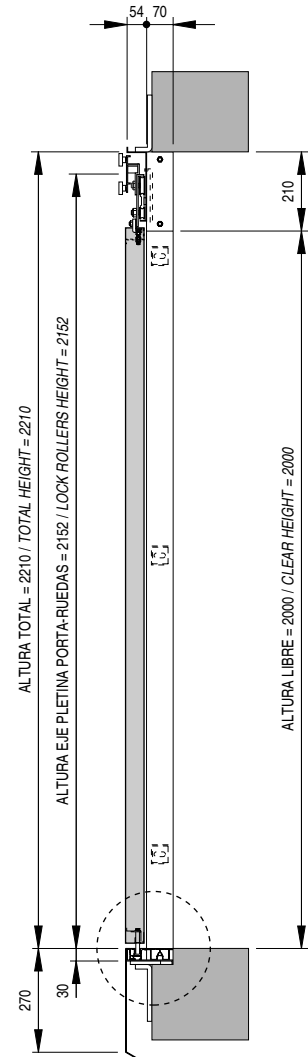
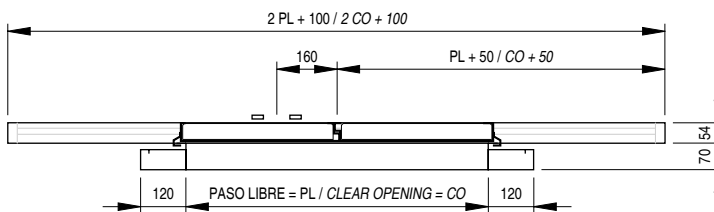
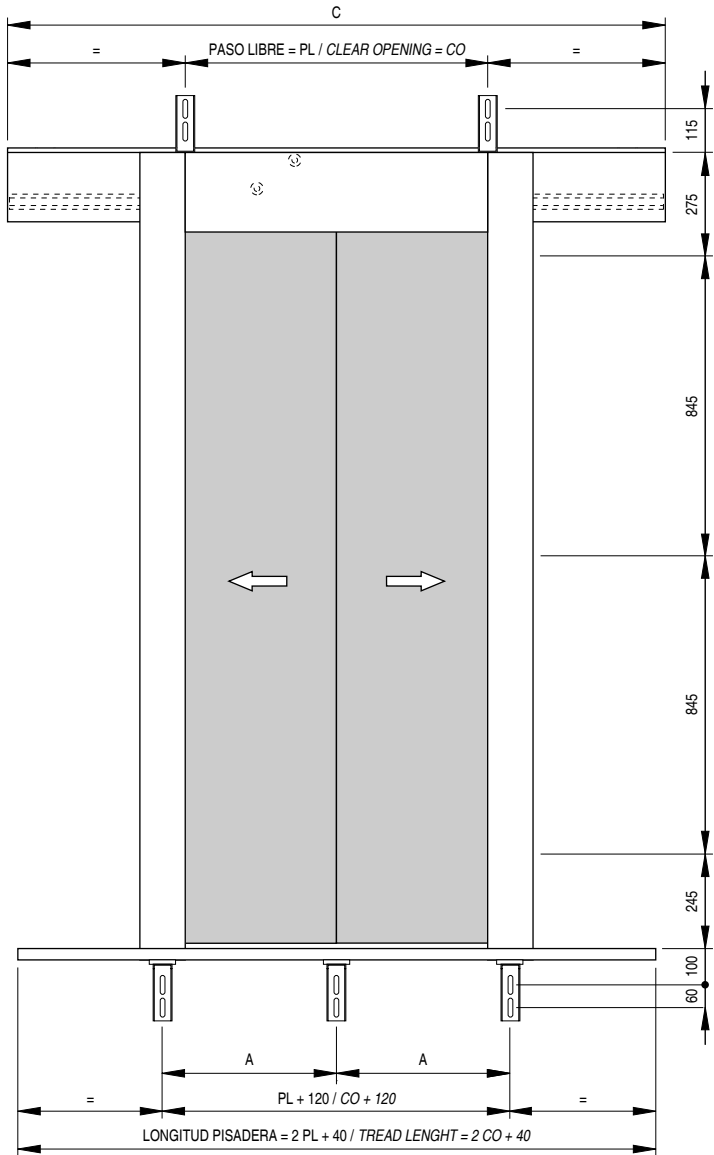

DETALLE
PISADERA
FLUSH SILL AND
TRACK DETAIL

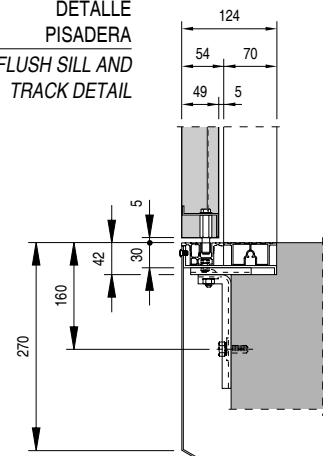

PL / CO	600	650	700	750	800	850	900	1000	1100	1200	1300	1400	1500	1600	1700	1800	1900	2000
C	1300	1400	1500	1600	1700	1800	1900	2100	2300	2500	2700	2900	3100	3300	3500	3700	3900	4100
A	360	385	410	435	460	485	340	373	407	330	355	380	324	344	303	320	337	303
S	3	3	3	3	3	3	4	4	4	5	5	5	6	6	7	7	7	8
T	5	5	5	5	5	5	6	6	6	8	8	8	9	9	10	11	11	12

S: N°. de soportes en apoyo pisadera.

T: N°. de soportes total.

S: Number of supports for support track.

T: Total number of supports.