

Puerta con un motor
Door with one motor

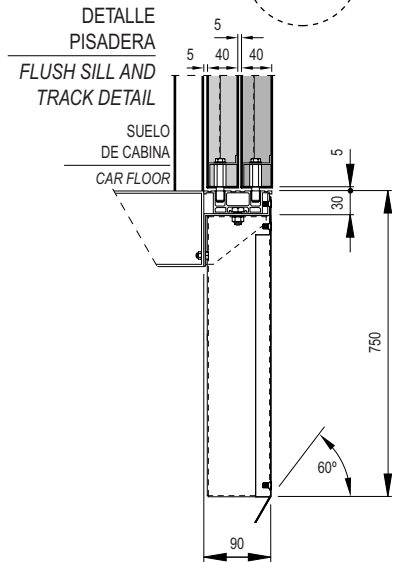
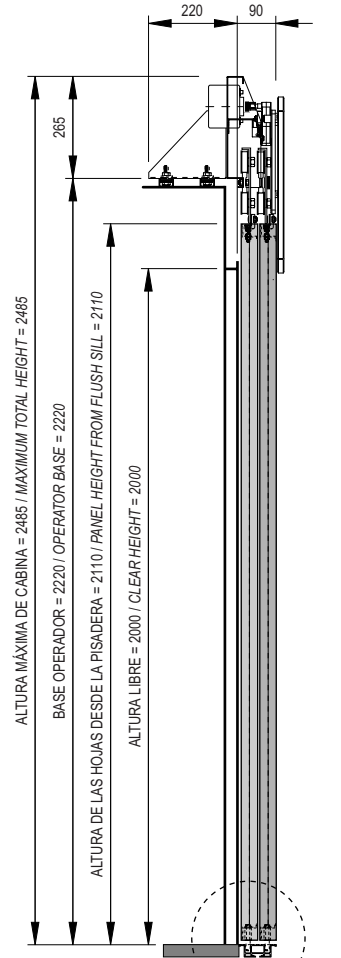
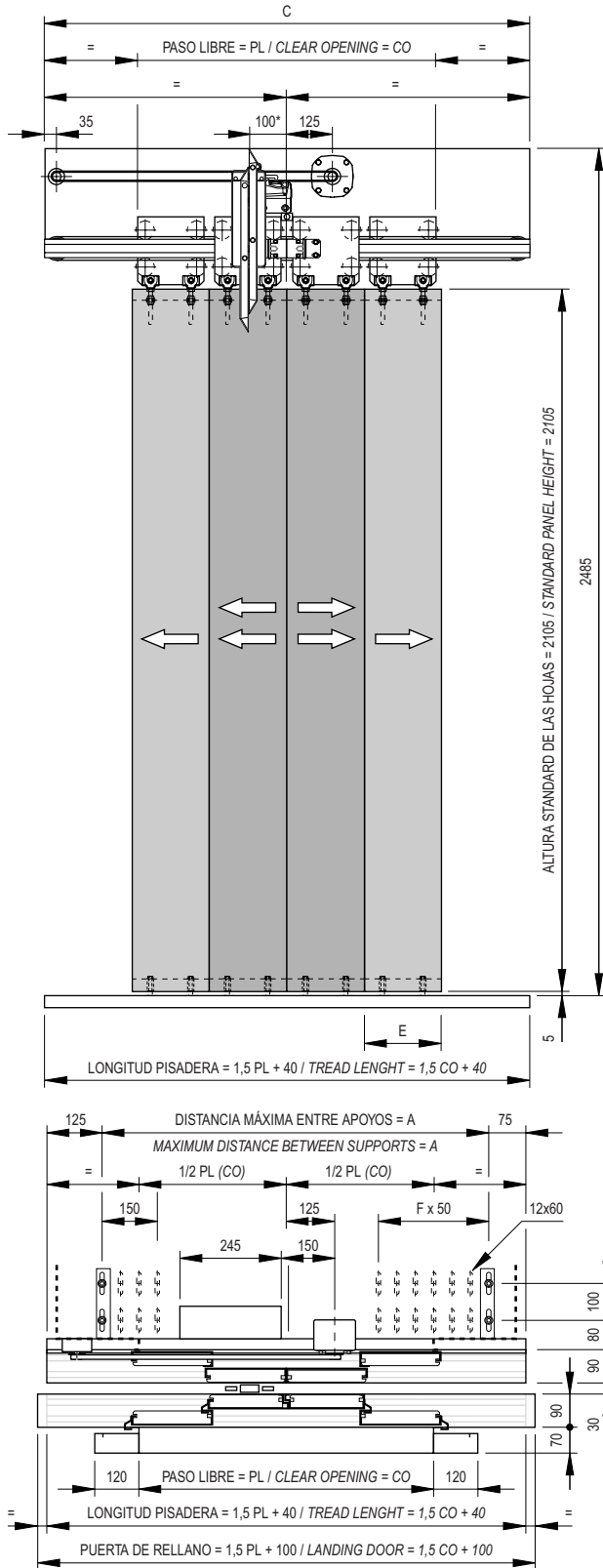

*: A PARTIR DE PL 950, COTA = 160
*: FROM THE CO 950, DIMENSION = 160

PL / CO	600	650	700	750	800	900	1000	1100
A	750	825	900	975	1050	1200	1350	1500
C	980	1025	1100	1175	1250	1400	1550	1700
E	170	182,5	195	207,5	220	245	270	295
F	4	4	5	5	6	6	7	7
TIEMPO / TIME (s)	1,22	1,27	1,32	1,37	1,41	1,5	1,58	1,66
PESO / WEIGHT (Kg)	61,5	67	72	77	82	92,5	102,5	113