

2.2.

PUERTA CABINA CENTRAL 4 HOJAS 4 PANEL CENTRE PARTING CAR DOOR

VVF

Fermator
AUTOMATIC DOORS FOR LIFTS

2

Puerta con dos motores
Door with two motors

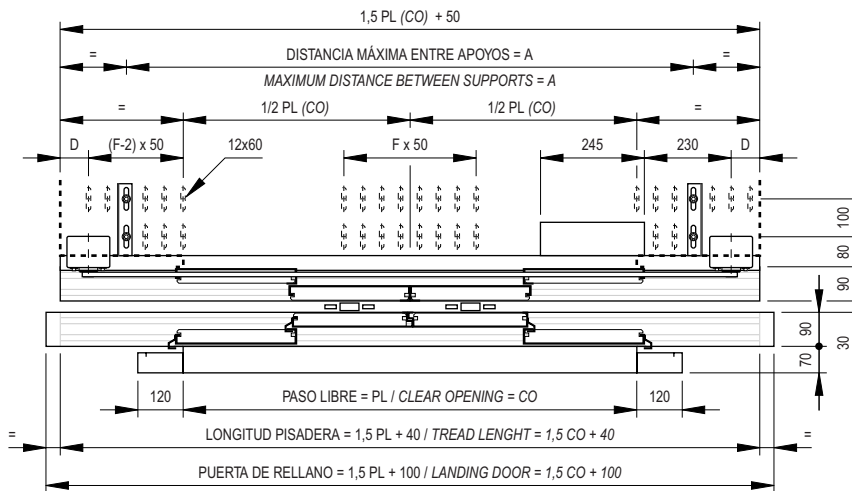
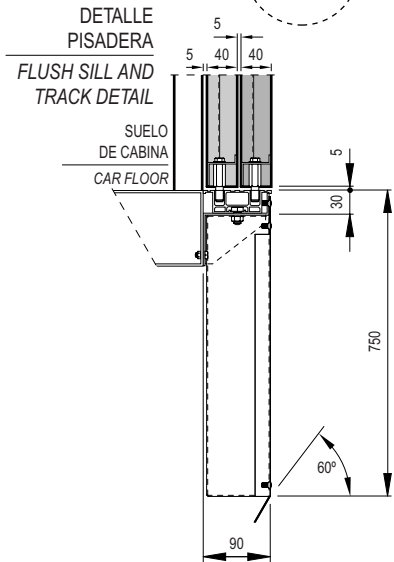
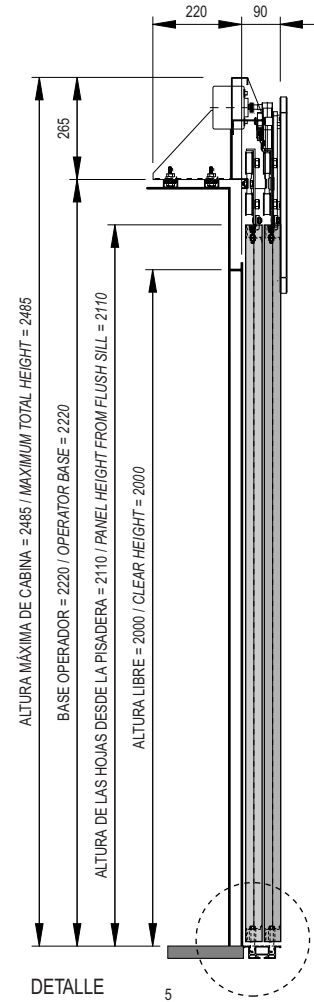
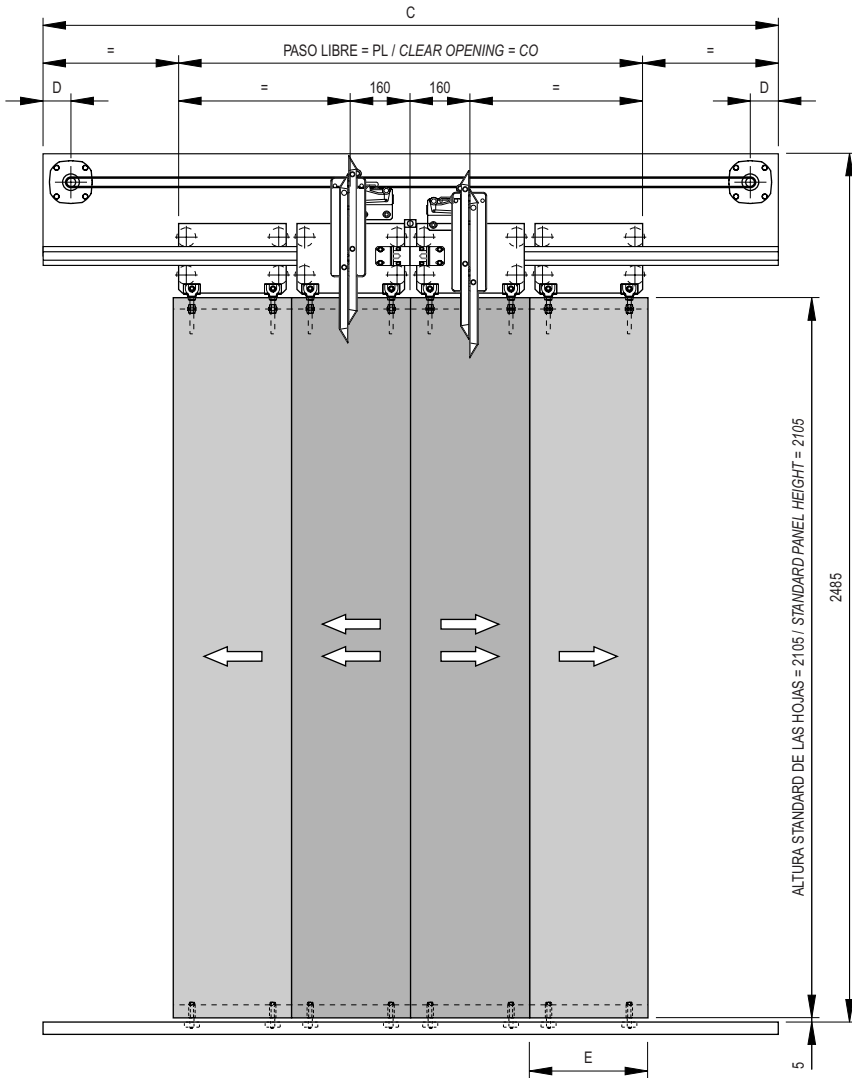

PL / CO	1200	1300	1400	1500	1600	1700	1800	1900	2000	2100	2200	2300	2400	2500	2600	2700	2800	2900	3000
A	1400	1550	1700	1850	2000	2150	2300	2450	2600	2750	2900	3050	3200	3350	3500	3650	3800	3950	4100
C	1850	2000	2150	2300	2450	2600	2750	2900	3050	3200	3350	3500	3650	3800	3950	4100	4250	4400	4550
D	88	88	125	125	125	175	175	225	225	277	277	325	325	375	375	425	425	475	475
E	320	345	370	395	420	445	470	495	520	545	570	595	620	645	670	695	720	745	770
F	4	4	4	4	5	5	5	5	5	5	5	5	5	5	5	5	5	5	5
TIEMPO / TIME (s)	1,73	1,8	1,87	1,94	2	2,06	2,12	2,18	2,24	2,29	2,35	2,4	2,45	2,5	2,55	2,6	2,65	2,7	2,75
PESO / WEIGHT (kg)	123	133,5	143,5	154	164	174,5	184,5	195	205	215,5	225,5	236	246	256,5	266,5	277	287	297,5	307,5